

AT400 / 401 / 402 EzyTRIGGER

The EzyTrigger is an economic replacement of pulse transformers including all associated circuitry in phase controlled thyristor equipment. Due to the small control current it becomes the ideal link between any size of thyristor and the control intelligence. Each EzyTrigger can trigger 2 thyristors and is intended for mains voltages from 115V to 690Vrms.

Its operation is based on an optically activated current source connected between anode and gate of the thyristor to be triggered. Thus a small electrically isolated control current initiates a large gate current without the necessity of a gate drive power supply. 3 different application specific types are available.

- AT400 Series - controlled rectifiers, ac controllers, dc motor control, all other applications
- AT401 Series - economic low cost ac controllers
- AT402 Series - zero crossing switching - heating, welding, power factor correction

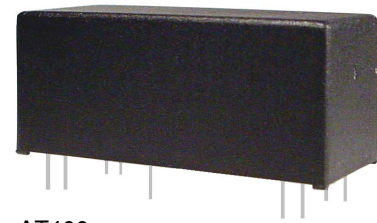

AT400



AT401

Actual Size

HIGHLIGHTS

Economic - very easy to use - small size - powerful gate pulse triggers large and small thyristors. Eliminates gate drive power supply - proven reliability in harsh industrial environment.

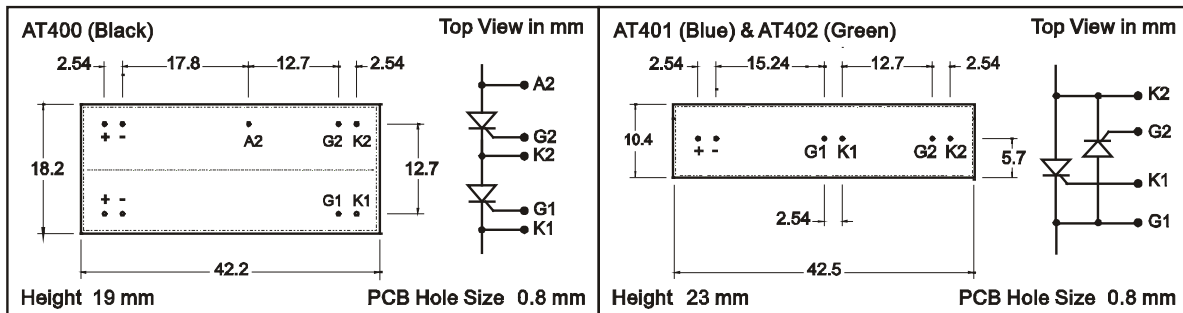

ABSOLUTE MAXIMUM RATINGS

Parameter	Symbol	Type			Unit
		AT400-12	AT400-22	AT400-24	
Peak voltage – positive and negative	Vp	1200	2100*	2400	V
Nominal mains voltage	Vm	400	690	690	Vrms
Continuous DC voltage	V=	400	690	690	Vdc
Turn-on delay for gate current > 1A	tgd	5	5	5	µs
Input-output isolation	Vi	5300Vrms 60Hz 1min VDE0884			
Input-output transient immunity	(dv/dt)c	5000			V/µs
Device transient immunity	(dv/dt)d	2000			V/µs
Ambient temperature range	Ta	-25 to +85			°C
External gate-cathode short circuit during operation can be destructive					

* 2200V for AT400-22 - For AT401-22 and AT402-22 with 2220V rating contact factory

TECHNICAL DATA at 25°C

Parameter	Symbol	Type			Unit	
		AT400-12	AT400-22	AT400-24		
		AT401-12	AT401-21			
		AT402-12	AT402-21			
200mA gate current threshold	Vgtl	10	16	16	V	
1.2A gate current threshold	Vgth	24	36	36	V	
Gate current rise time at anode voltage of	(di/dt) _g	100V	2.5	1.2	1.2	A/μs
		200V	3	2	2	A/μs
		400V	4	2.5	2.5	A/μs
		800V	6	3	3	A/μs
		1200V		4	4	A/μs
Peak gate current (typical)	Ip	1.3	1.3	1.3	A	
Anode-cathode current at V _p	I _n	4.4	5.1	5.8	mA	
Maximum off state gate current	I _o	2*	2*	2	μA	
Minimum control current	I _{cm}	7	7	7	mA	
Recommended control current	I _c	12	12	12	mA	
Control input voltage drop at 12mA	V _{in}	typ 1.2 <1.5	typ 1.2 <1.5	typ 1.2 <1.5	V	
Maximum reverse control input voltage	V _{inr}	6	6	6	V	
Turn-on delay time at I _c =12mA	t _{di}	25	25	25	μs	
Zero crossing threshold for AT402	V _{zt}	<20	<20	-	V	

*AT402 <40μA

APPLICATION INFORMATION

Because the gate current is derived from the anode of the thyristor, the control circuit only needs to supply the recommended control current, which can be supplied directly from the output of many logic devices. It is advisable to maintain the control current over the entire conduction period of the thyristor. Once the thyristor is triggered, the gate current ceases to flow because the anode voltage drops below the threshold voltage.

The control input consists of the light emitting diode of an optocoupler. Any such optical component is subject to aging at elevated temperatures. Although the minimum control current I_{cm} is well below 7mA, a 12mA control signal is recommended to ensure reliable operation beyond 100'000 hours in a worst case design. The turn-on delay t_{di} can be reduced by pulse shaping, because it is inversely proportional to the control current.

Because the device derives its power from the anode of the thyristor, a minimum operating voltage is required before any current can flow from the anode to the gate. This threshold voltage limits the minimum regulated output voltage. For example for a single-phase 115V ac controller triggered by a 1200V unit it is below 0.12%. For a 400V supply it is much less and can safely be neglected in most applications.

The thyristor is triggered from a current source with a maximum voltage of 22V. This allows for twisted gate leads of up to 1m while maintaining a high rate of rise of the gate current.

Note that the envelope of the voltage across the thyristor to be triggered can have any desired shape provided the rms value is below V_m and the peak value does not exceed V_p.

Both the AT401 and the AT402 have one control input only. This means that the thyristor with a positive anode voltage will be triggered when a control signal is present.

The connection diagrams below shows the typical application of the EzyTrigger in mains operated systems using thyristors with current ratings from a few Amps up to several thousand Amps.

CONNECTING DIAGRAMS

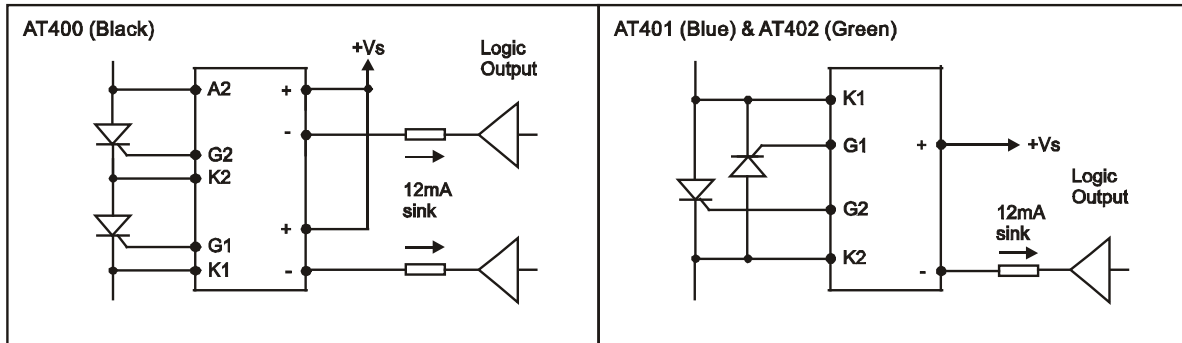

CONTACTS

BSR Controls - Canada

4706 Woodley Dr. West Vancouver V7S 3A1
Canada

☎ +1 604 925 0051 📠 +1 604 925 0602

canadasales@bsrcontrols.com

BSR Controls CC - South Africa

P.O.Box 427, Clanwilliam 8135
South-Africa

☎ +27 27 482 2246 📠 +27 27 482 1611

sasales@bsrcontrols.com

Lectron Industries

979 Lehigh Avenue
Union, NJ 07083
USA

☎ +1 908 687 2626 📠 +1 908 687 5678

sales@lectronindustries.com

Website: www.bsrcontrols.com